

CZ PŮDNÍ SCHODY

DE BODENTREPPE

EE PÕÕNINGUREDEL

ES ESCALERAS ESCAMOTEABLES

FR ESCALIER ESCAMOTABLE

GB LOFT LADDER

HU PADLÁSFELJÁRÓ LÉPCSŐ

IT LE SCALE PER LA SOFFITTA

LT PALĖPĖS LAIPTELIAI

LV BĒNIŅU KĀPNES

NL ZOLDER/VLIERINGTRAP

PL SCHODY STRYCHOWE

PT ESCADA DE SOTAO-ENCAIXADA

RO SCARĂ MODULARĂ

RU ЧЕРДАЧНАЯ ЛЕСТНИЦА

SI PODSTREŠNE SLOPLJIVE STOPNICE

SK STROPNÉ SKLÁPACIE SCHODY

UA СХОДИ НА ГОРИЩЕ

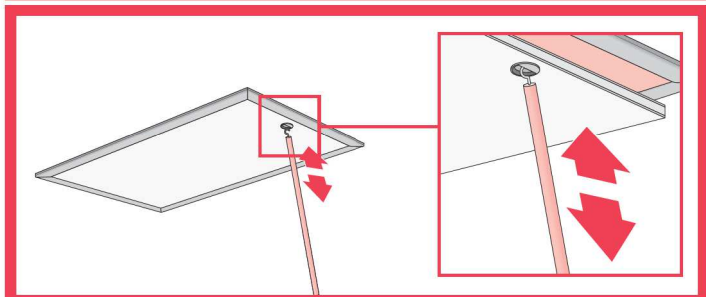
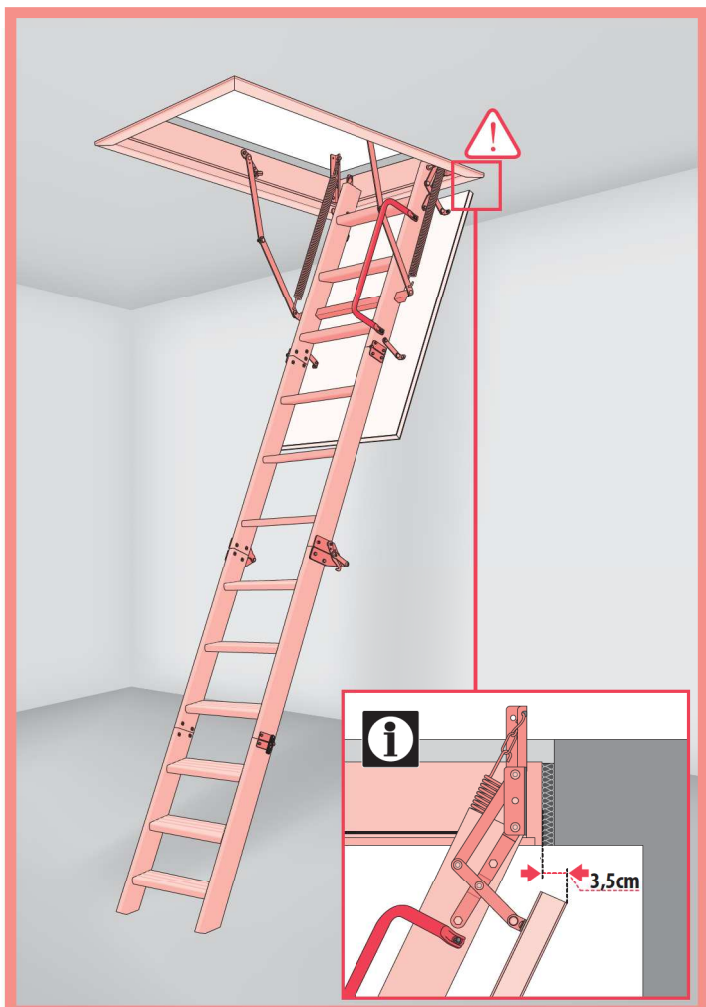

HYGRO
RH MAX 80%





**WARNING! ACHTUNG!
U W A G A ! ATTENTION!
CUIDADO! ПРИМЕЧАНИЕ!**

CZ Montáž schodů je nutno provést v souladu s návodem. POZOR! Použití schodů v rozporu s návodem je zakázáno, může způsobit vážnou nehodu a má za následek ztrátu záruky a odpovědnosti výrobce.

DE Die Montage und Nutzung der Bodentreppe sollte gemäß der Anleitung durchgeführt werden. ACHTUNG! Die Nichtbeachtung der Anleitung ist verboten und kann schwere Unfälle verursachen und ist aus der Garantie ausgeschlossen. Der Hersteller übernimmt keine Verantwortung.

EE Pööninguluugi paigaldus ja kasutamine peab olema vastavuses lisatud juhenditega. TÄHELEPANU! Juhistele mitte vastav kasutamine on rangelt keelatud kuna võib põhjustada tõsise õnnetuse, see tühistab garantii ning muudab Tootja toote eest enam mitte vastutavaks.

ES La instalación y el uso de las escaleras se debe ejecutar de acuerdo con el manual de instrucciones. ¡PRECAUCIÓN! Está prohibida la utilización de la escalera que no sea conforme con el manual de instrucciones, porque puede causar un accidente grave, deshabilita la garantía y hace que el fabricante no se responsabilice.

FR L'installation et l'utilisation des escaliers doivent être effectuées conformément à l'instruction. ATTENTION! L'utilisation des escaliers contrairement à l'instruction est interdite, elle peut provoquer un accident grave, annulation de la garantie et manque de responsabilité du fabricant.

GB Installation and use of the loft ladder should be strictly in accordance with included instructions. CAUTION! Using the loft ladder in violation of the instructions is strictly forbidden, may result in a serious injury, will invalidate the Warranty and makes the Manufacturer no longer liable for the product.

HU A padlásfeljáró lépcső beépítése és üzemeltetése a beépítési/használati útmutató szerint kell, hogy történjen! FIGYELEM! A padlásfeljáró lépcső útmutatóval ellentétes vagy azzal nem megegyező módon történő használata tilos és balesetveszélyes, illetve súlyos balesettel járhat valamint garanciavesztést eredményez; a fentiekből adódó következményekért a gyártó nem vállal semmiféle felelősséget.

IT L'installazione e l'uso va fatto nel pieno rispetto delle istruzioni. ATTENZIONE! è assolutamente vietato l'utilizzo difforme alle istruzioni d'uso dato che può essere causa di gravi incidenti ed in ogni caso fa decadere la garanzia nonché qualsiasi responsabilità del produttore.

LT Montuojant ir naudojantis palėpės laiptais būtina laikytis nurodytų instrukcijų. ĮSPĖJIMAS: naudotis palėpės laiptais pažeidžiant instrukcijas griežtai draudžiama, nes tai gali sukelti rimtą nelaimingą atsitikimą, ir gamintojas turi teisę panaikinti garantiją ir nebeatsakyti už gaminį.

LV Bēniņu kāpņu uzstādīšana un lietošana veicama atbilstoši pievienotajām instrukcijām. UZMANĪBU! Kāpņu lietošana neatbilstoši instrukcijas prasībām ir stingri aizliegta, jo tā var izraisīt nopietnus nelaimes gadījumus, kā arī pārtrauc noteikto garantijas apkalpošanu un ražotāja atbildību par produktu.

NL Het is noodzakelijk dat montage en gebruik van de zoldertrappen conform de handleidingen uitgevoerd worden. LET OP! Gebruik van de zoldertrap is niet toegestaan wanneer deze niet conform de handleiding is gemonteerd. Dit kan gevaarlijke situaties veroorzaken. De garantie wordt in dit geval niet toegekend en de producent is niet verantwoordelijk voor de mogelijke gevolgen.

PL Montaż i użytkowanie schodów należy wykonywać zgodnie z instrukcją. UWAGA! użytkowanie schodów niezgodnie z instrukcją jest zabronione, może spowodować groźny wypadek, wyłącza gwarancję oraz powoduje brak odpowiedzialności producenta.

PT A instalação e o uso da escada devem ser de acordo com as instruções incluídas. ATENÇÃO! O uso da escada violando as instruções é estritamente proibido, pois isso pode causar um acidente grave, anula a Garantia e torna o Fabricante não responsável pelo produto

RO Instalarea și utilizarea scărilor trebuie efectuate conform instrucțiunilor. ATENȚIE! Încălcarea acestor instrucțiuni este interzisă deoarece duce la pierderea garanției și poate provoca accidente grave. Producătorul nu își asumă răspunderea pentru evenimentele produse ca urmare a încălcării instrucțiunilor de instalare și utilizare a scărilor.

RU Монтаж и эксплуатация лестницы должны проводиться согласно инструкциям производителя. ВНИМАНИЕ! Неправильная эксплуатация лестницы может привести к несчастному случаю, отменить гарантию производителя и снять с него ответственность.

SI Namestitev in uporaba podstrešja morajo biti v skladu z vključenimi navodili. OPOZORILO! Uporaba lestve podvozja v nasprotju z navodili je strogo prepovedana, saj lahko povzroči resno nesrečo, razveljavi garancijo in povzroči, da proizvajalec ne odgovarja več za izdelek.

SK Montáž a používanie schodov je potrebné vykonávať v súlade s návodom. POZOR! Používanie schodov v rozpore s návodom je zakázané, môže spôsobiť vážnu nehodu a má za následok stratu záruky a zodpovednosti výrobcu.

US Installation and use of the attic ladder should be in accordance with included instructions. WARNING! Using the attic ladder in violation of the instructions is strictly forbidden as it may cause a serious accident, it voids the Warranty and makes the Manufacturer no longer liable for the product.

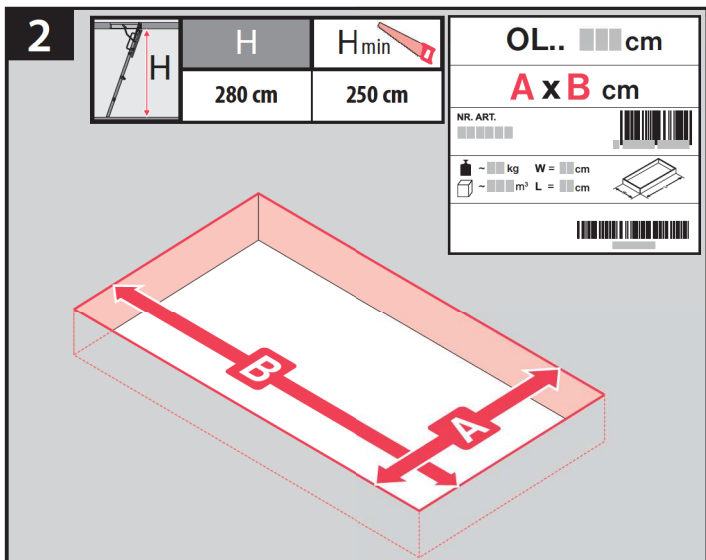
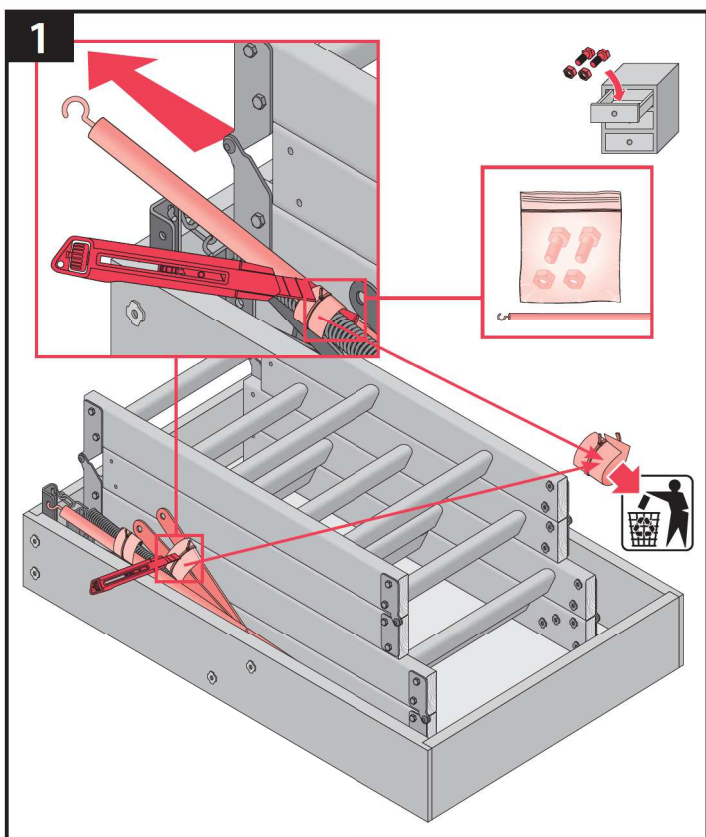
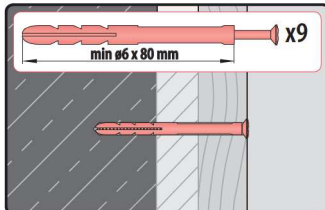
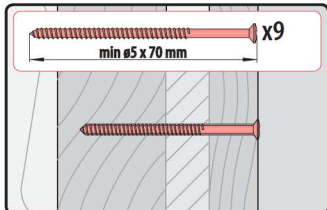
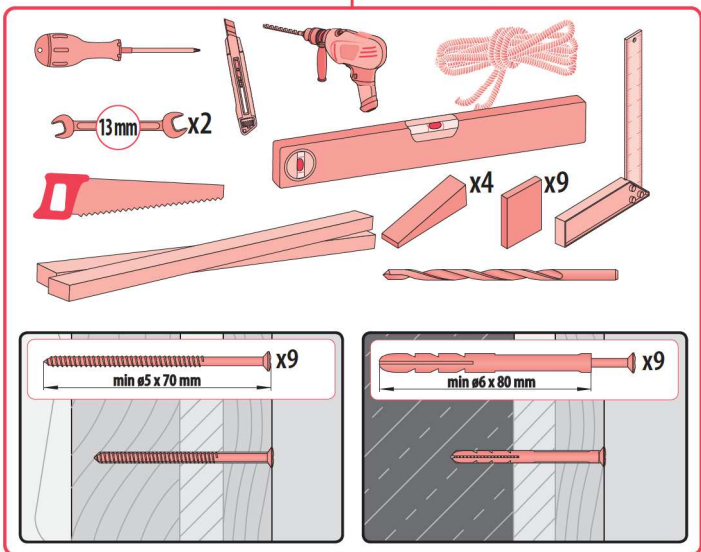

3

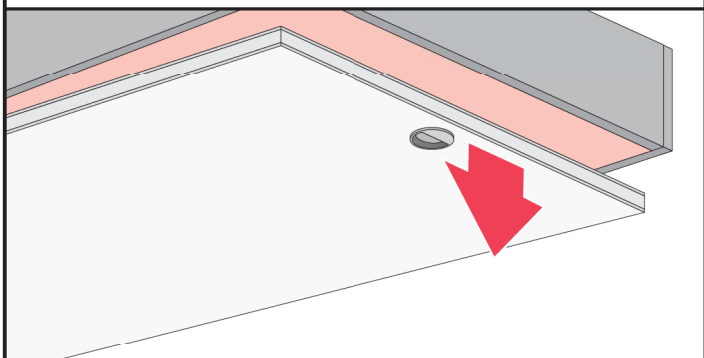
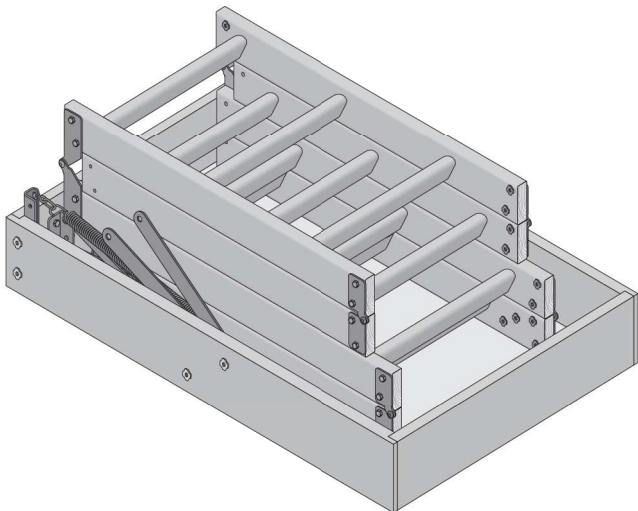

4

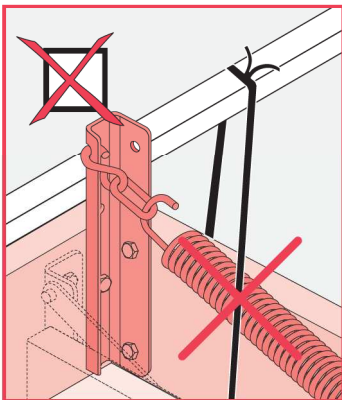
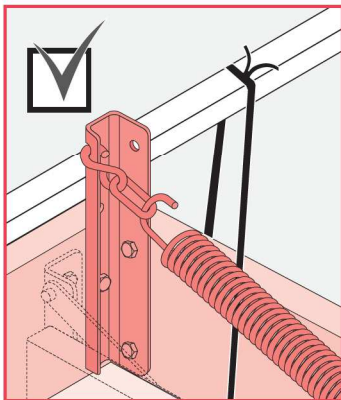
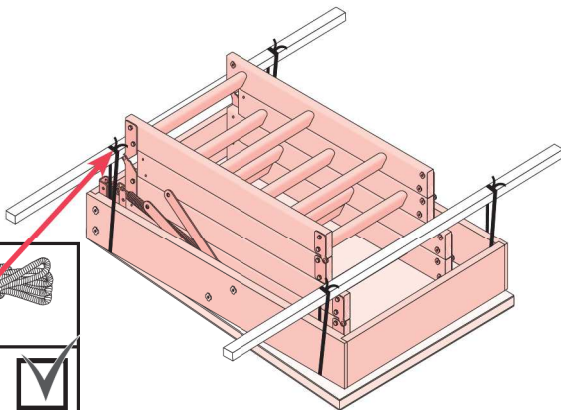

5

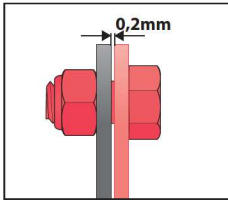
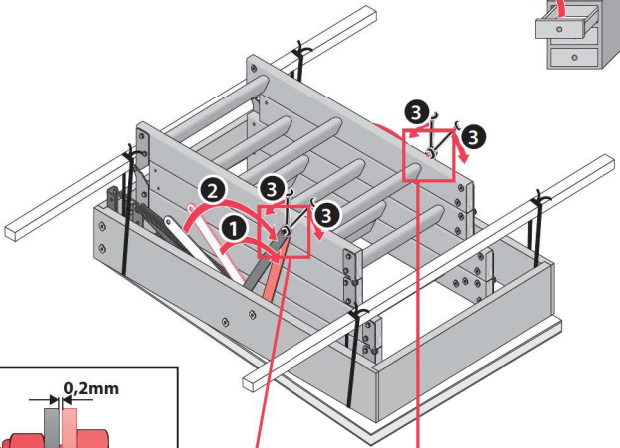
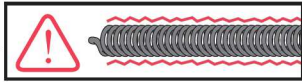

L

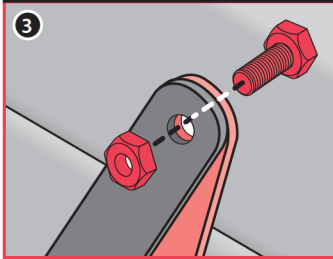

R

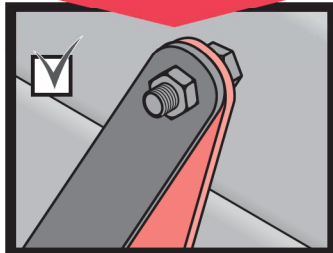
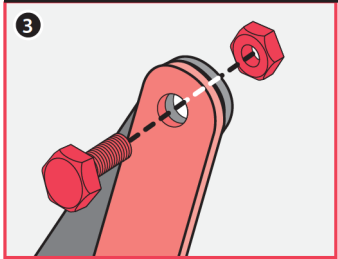

6

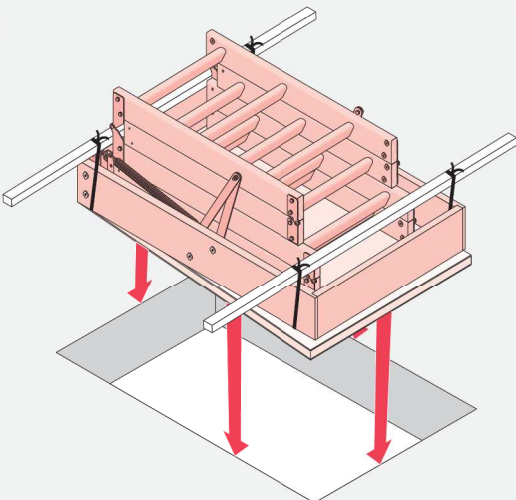

7

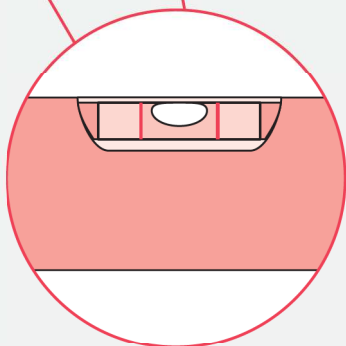
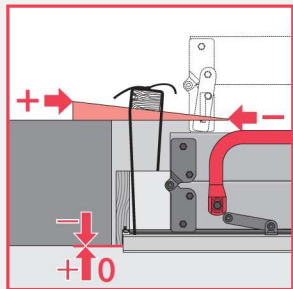
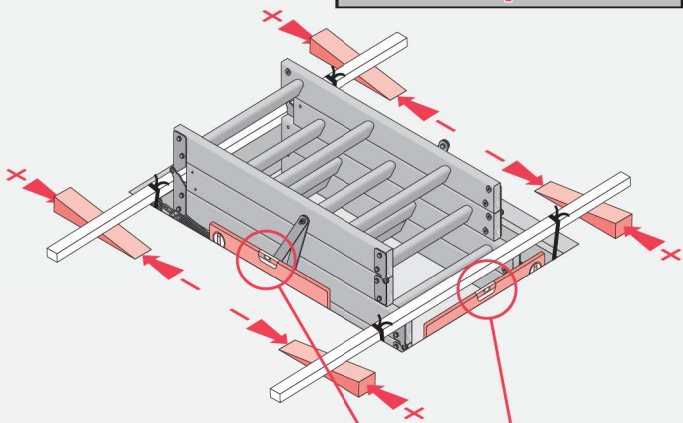
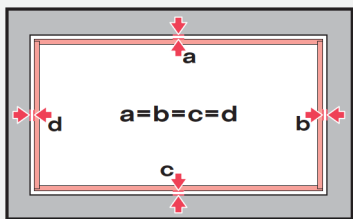

8

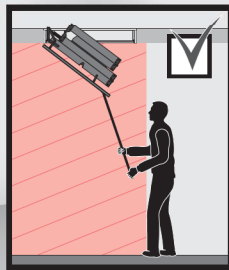
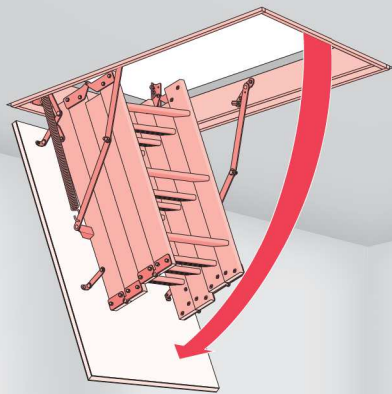
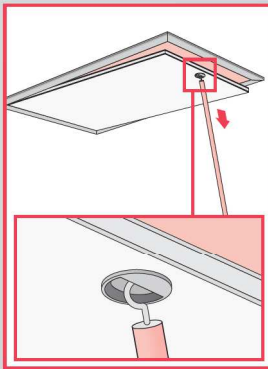

9



7*

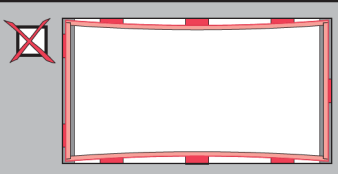
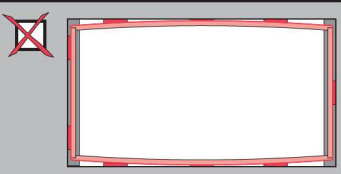
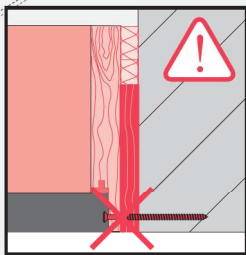
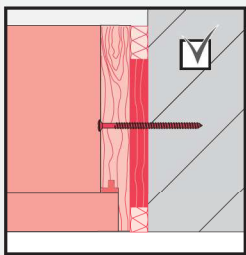
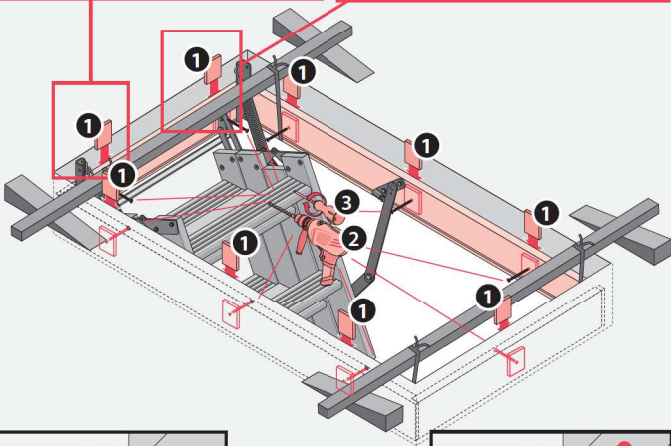
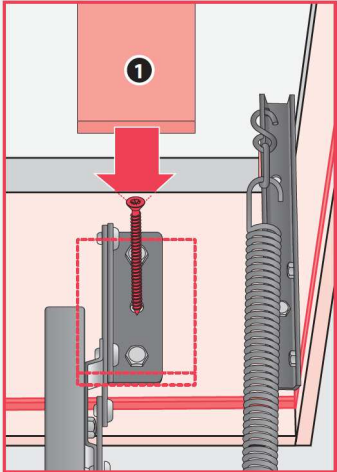
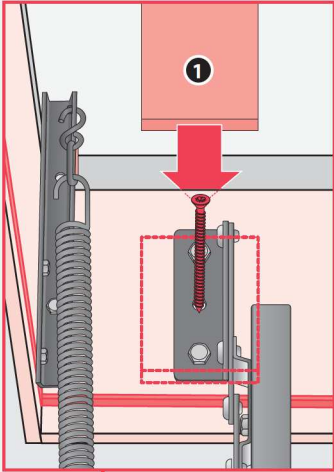

 THERMO INSULATION

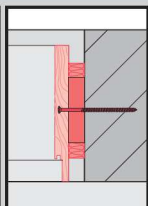
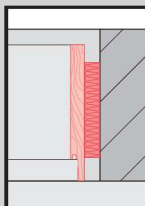
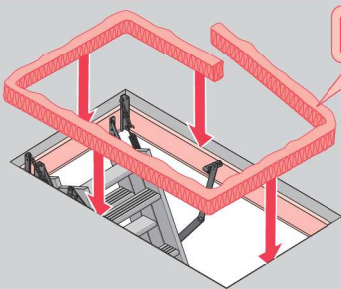

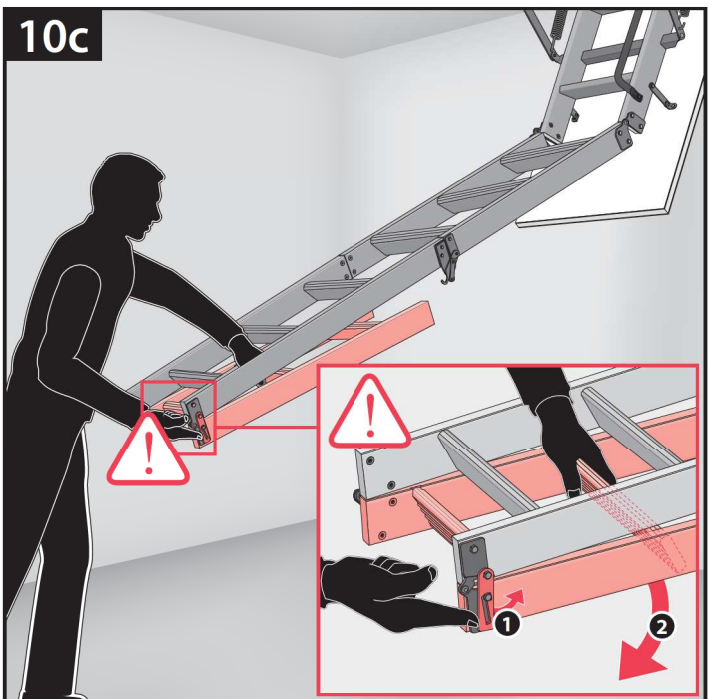
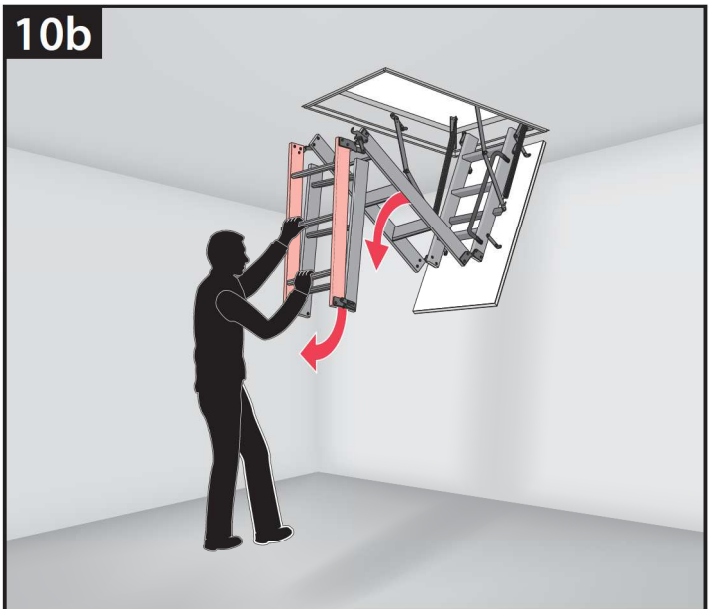
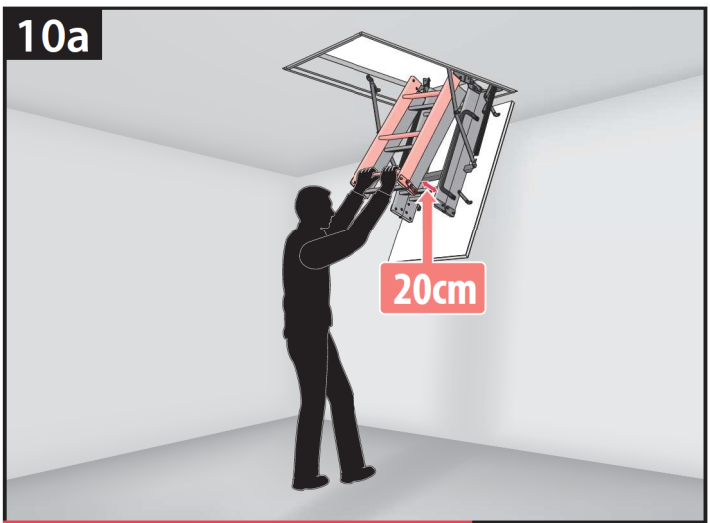

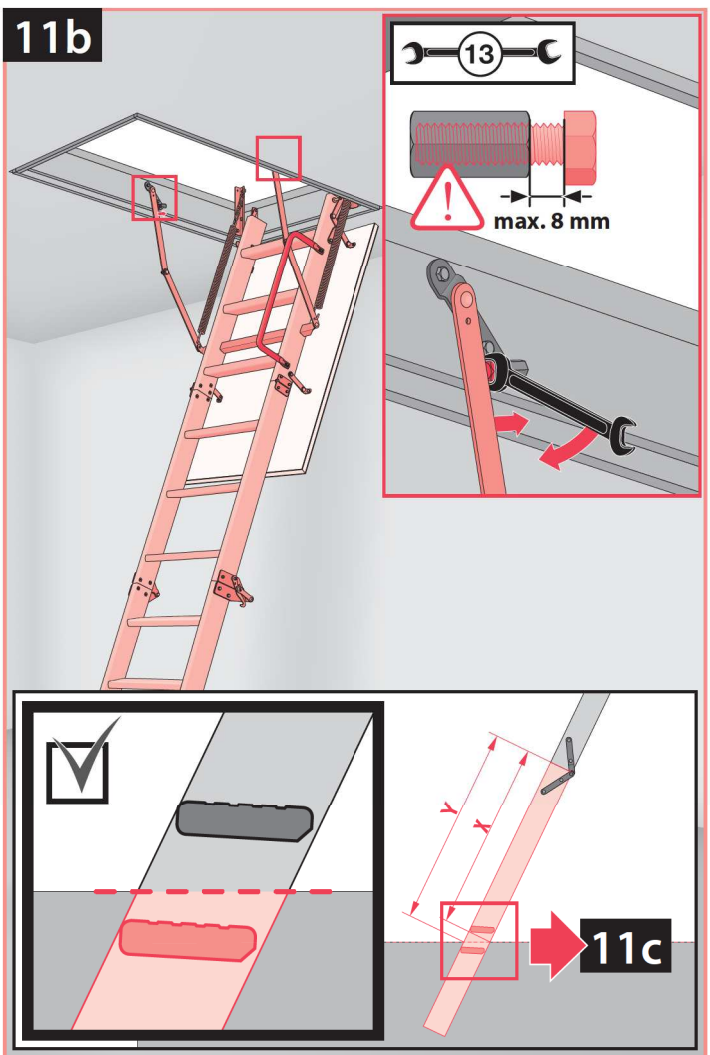
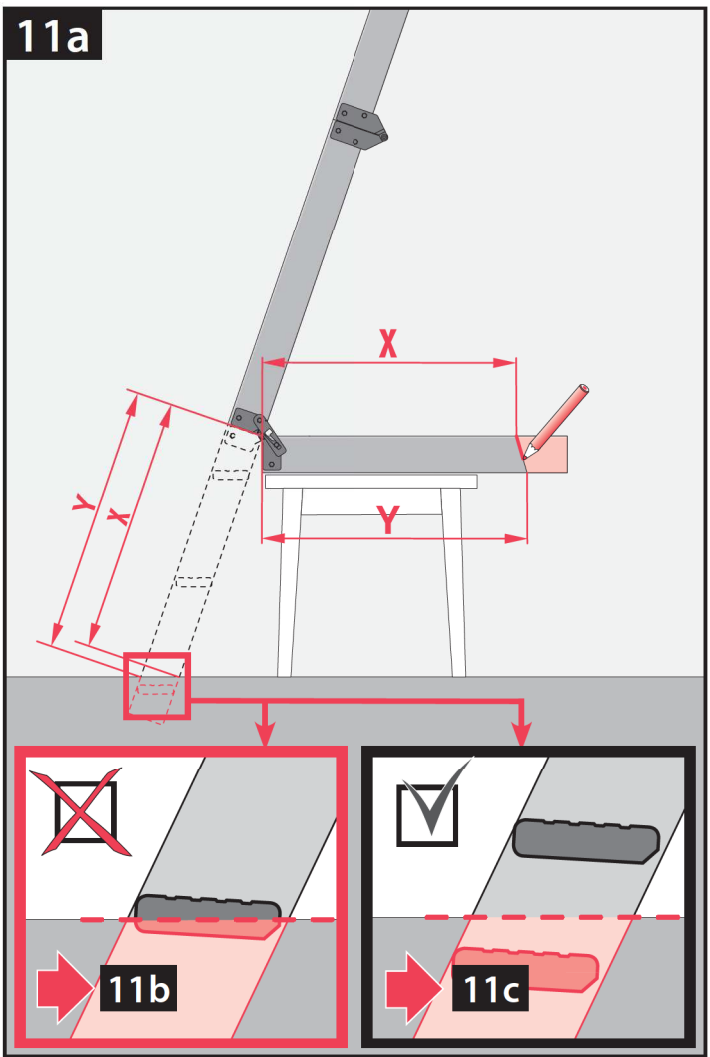

11c

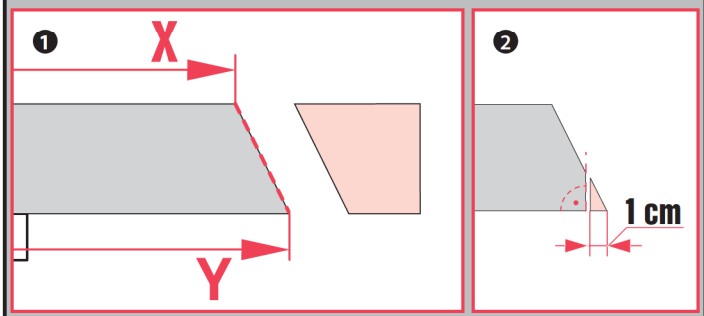
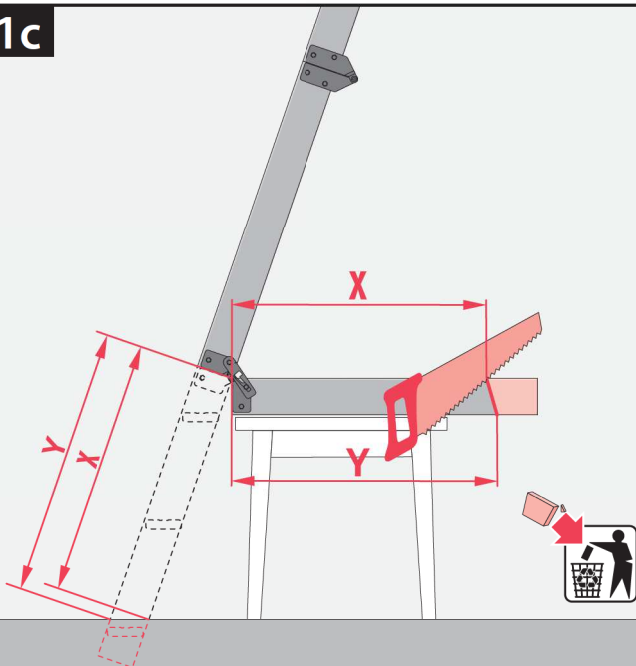

12a

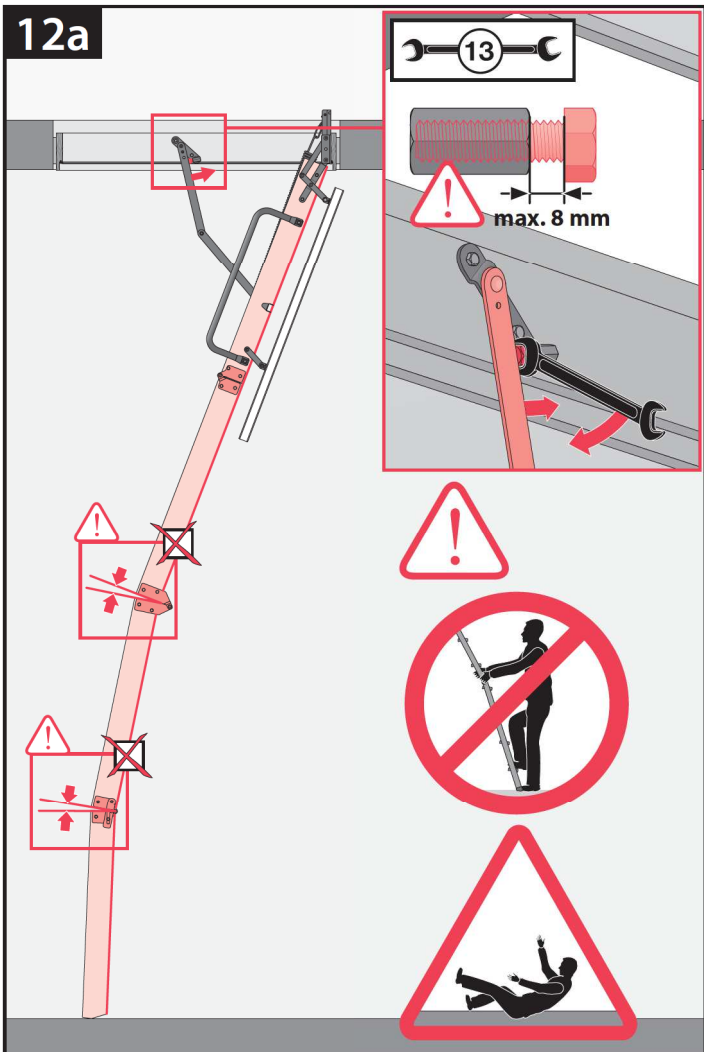

12b

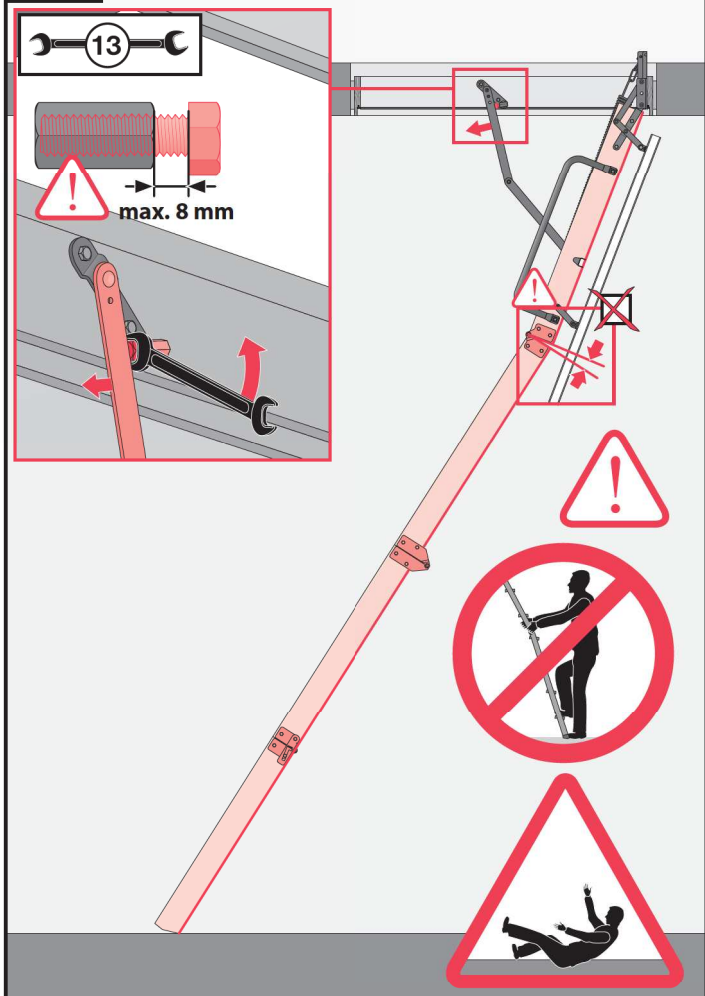

12c

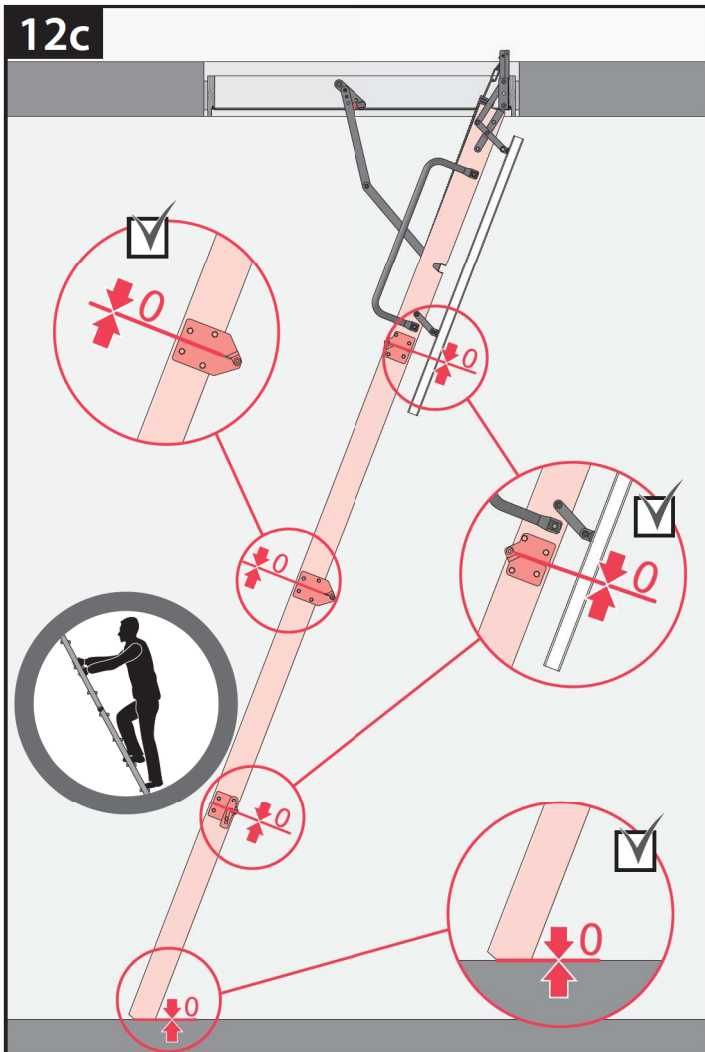

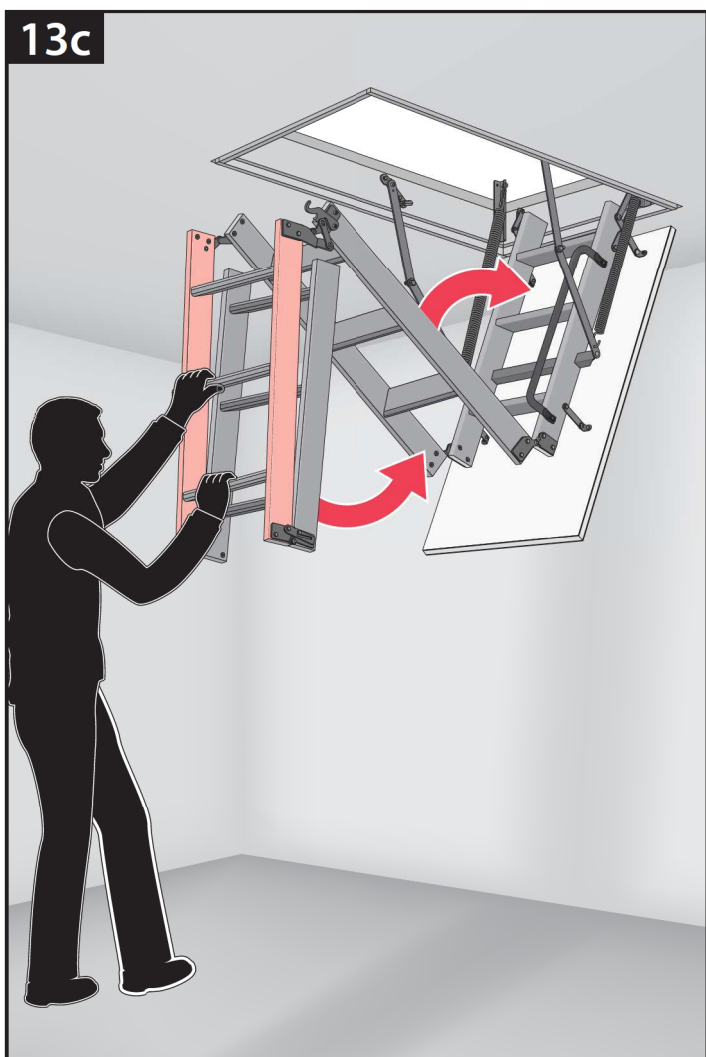
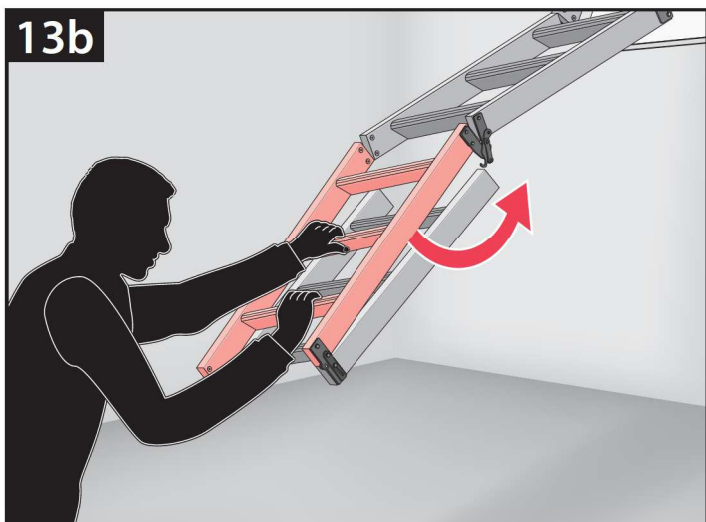
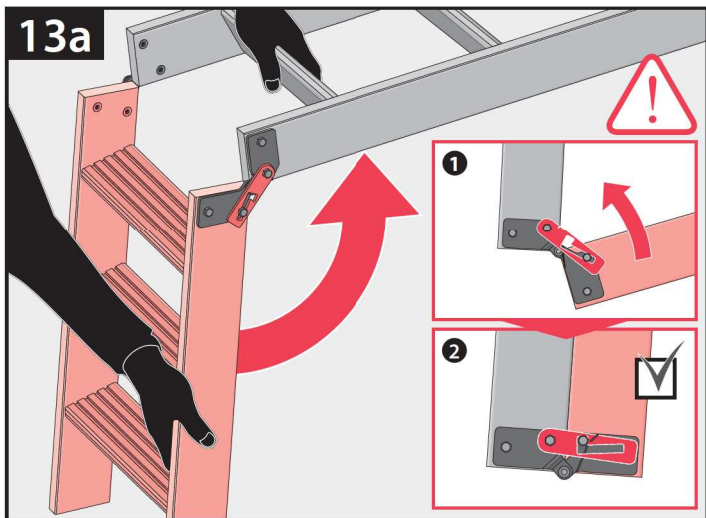

13d

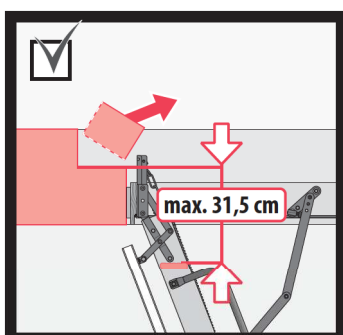
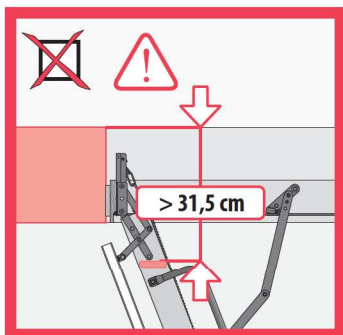
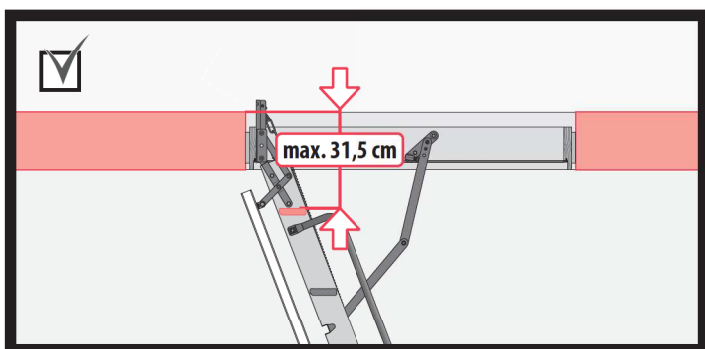
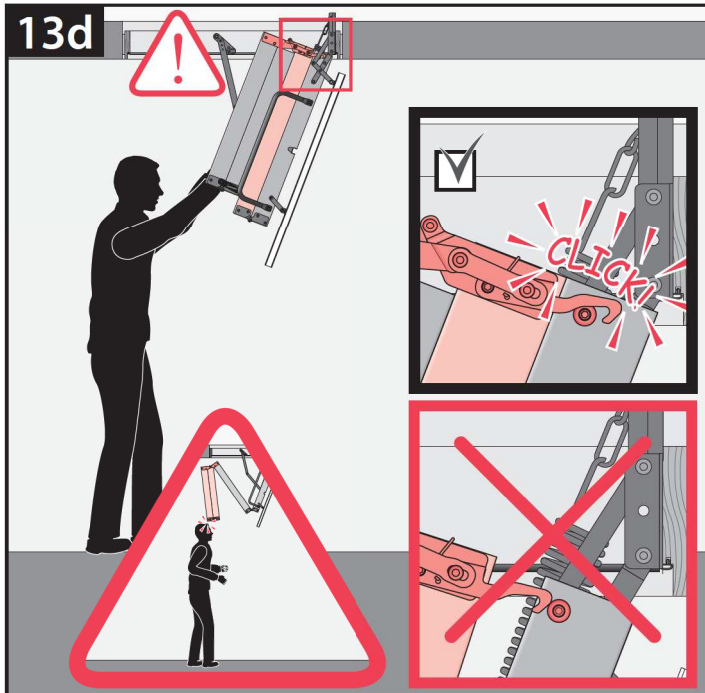

**

DE Bodentreppen sind erst nach der Ausführung von feuchten Bauarbeiten einzubauen, wenn die Baufeuchte wieder auf ein für Aufenthaltsräume normales Maß zurückgegangen ist. Die Bodentreppen sind nur für Verwendung in trockenen Innenräumen geeignet.

EE Pööninguredel on ette nähtud paigaldamiseks peale "märgade" sisetööde lõpetamist kui niiskustase on normaliseerunud. Pööninguredelit võib kasutada ainult kuivades siseruumides.

ES La escalera se debe instalar una vez que la instalación se encuentre totalmente seca. Se aconseja montar la escalera en la estancia donde la humedad esta por debajo de 80%. Las escaleras son para uso en interior y en espacios secos.

FR L'escalier doit être monté après la finition des travaux de finition humide, lorsque l'humidité dans le bâtiment atteint une valeur appropriée pour locaux secs. Escaliers sont destinés à usage interne et uniquement dans les endroits secs.

GB The loft ladder should be installed after completion of wet works, when the humidity in the building reaches the value appropriate for dry rooms. Loft ladders are designed for the interior use and only in dry rooms.

LT Palėpės laiptus reikia montuoti name užbaigus šilumos statybos procesus, ir tik tada kai drėgmė patalpoje atitinka sauso namo reikalavimus. Palėpės laiptus galima montuoti tik namo viduje ir sausose patalpose.

LV Bēniņu kāpnes drīkst uzstādīt tikai pēc tam, kad pabeigti ar mitruma izdalīšanos saistītie celtniecības darbi, un mitruma līmenis ēkā ir sasniedzis sausām telpām paredzēto. Bēniņu kāpnes ir piemērotas iekšējām un tikai sausām telpām.

PL Schody należy montować po zakończeniu prac mokrych, gdy wilgotność w budynku osiągnie wartość właściwą dla pomieszczeń suchych. Schody przeznaczone są do użytku wewnętrznego i tylko w suchych pomieszczeniach.

RU Лестницу монтировать после завершения всех отделочных работ, то есть тогда, когда влажность в здании достигнет значения, соответствующего значению влажности в сухом помещении. Лестница предназначена для установки внутри сухого помещения.

! WARNING! - ACHTUNG! - UWAGA! - ATTENTION! - CUIDADO! - ВНИМАНИЕ! - BИМАНИЕ!

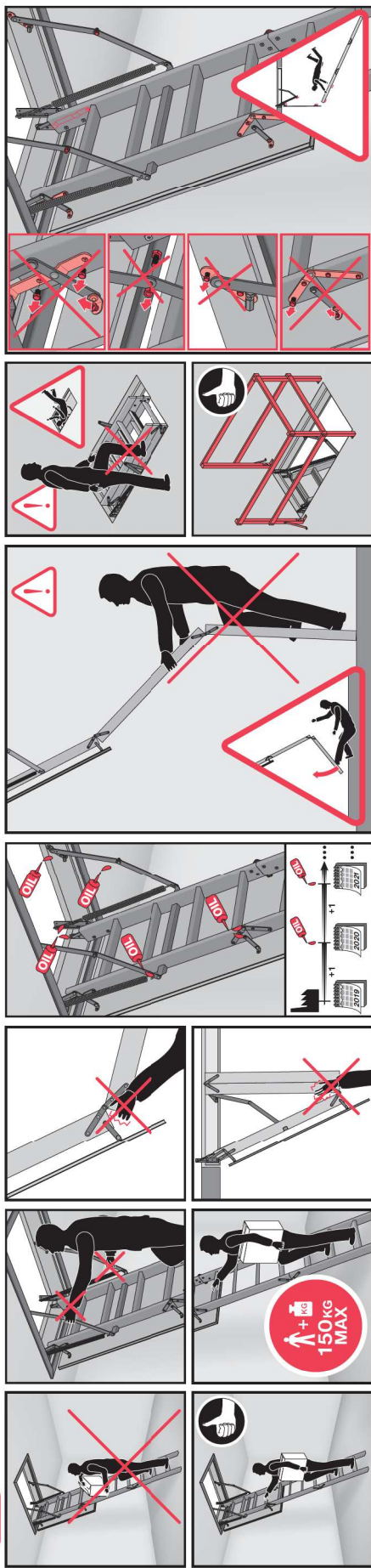

| | | | |
|-----------|--|-----------|--|
| CZ | Výrobce ani prodejce nenesou žádnou odpovědnost za nedodržení příslušných platných zákonů, státních předpisů a bezpečnostních požadavků uživateli výrobku, architektem, montážníkem nebo vlastníkem budovy. | NL | De fabrikant en verkoper zijn niet aansprakelijk voor gevolgen bij het niet opvolgen van toepasselijke wetten, bouwvoorschriften en veiligheidsvoorschriften door de gebruiker van het product, de architect, de installateur of de eigenaar van het gebouw. |
| DE | Hersteller und Verkäufer übernehmen keine Haftung für Nichtbeachtung entsprechender Rechts- und Bauvorschriften sowie Sicherheitsanforderungen seitens Produktbenutzers, Architekten, Monteure oder Gebäudebesitzer. | PL | Producent i Sprzedawca nie ponosi żadnej odpowiedzialności za nieprzestrzeganie stosownych przepisów prawa, przepisów budowlanych i wymogów bezpieczeństwa przez użytkownika produktu, architekta, montażystę lub właściciela budynku. |
| ES | El fabricante y el vendedor no tienen ninguna responsabilidad por el incumplimiento de la ley vigente, normas de construcción y exigencias de seguridad por parte del usuario del producto, arquitecto, instalador o el propietario del edificio. | PT | O fabricante e o vendedor não tem nenhuma responsabilidade pelo o não cumprimento da lei, códigos de construção e as exigências de segurança por parte do usuário do produto, arquiteto, instalador ou proprietário do edifício. |
| FR | Le fabricant et le revendeur ne prend aucune responsabilité de ne pas respecter les lois applicables, les règlements sur les bâtiments et les exigences de sécurité par l'utilisateur du produit, l'architecte, l'installateur ou le propriétaire du bâtiment. | RO | Nici producătorul, nici distribuitorul nu își vor asuma niciun fel de răspundere pentru nerespectarea legilor în vigoare, a legilor din domeniul construcțiilor sau a măsurilor de siguranță impuse utilizatorilor produsului, arhitecților, montajorilor sau proprietarilor clădirii. |
| GB | Manufacturer and Seller shall bear no liability for failure to comply with the applicable laws, building codes and safety requirements by the user of the product, architect, fitter or owner of the building. | RU | В случае несоблюдения архитектором, монтажником или владельцем здания строительных правил и норм безопасности ответственность с производителя и продавца снимается. |
| HU | A Gyártó és a Forgalmazó nem vállal semmiféle felelősséget a vonatkozó törvényi, építési és biztonsági előírások termékfelhasználó, építész, beépítőmester vagy épülettulajdonos általi nem tartásáért. | SK | Výrobca a predajca nenesú žiadnu zodpovednosť za nedodržanie príslušných ustanovení zákona, stavebných predpisov a bezpečnostných požiadaviek užívateľom výrobku, architektom, montážom alebo majiteľom objektu. |
| IT | Il Produttore e il Rivenditore non potranno essere ritenuti responsabili per il mancato rispetto, da parte dell'utente del prodotto, del progettista, dell'installatore o del proprietario dell'edificio, delle leggi vigenti, nonché dei regolamenti edilizi e di quelli relativi alla sicurezza. | | |